

Configurations

Category	Item	Status	Category	Item	Status	
Safety	Steering deceleration	●	Comfort	Semi-enclosure seat	●	
	Rear handle with horn for truck reversing	●		Full suspension seat	○	
	Overspeed alarm (5km/h)	○		1 USB interface (5V/1A)	●	
	Overspeed alarm (8km/h)	○		Super low torque steering unit	●	
	Overspeed alarm (10km/h)	○		Mechanical control valve	○	
	Speed limit (no ultimate limit type)	○		Fan	○	
	OPS(travelling+lifting+tilting+attachment lowering is not included)	●	Cab/ Windshields	Panel mounted cab (with fan and wiper)	○	
	Full set of OPS	○		Heater	○	
	Safety switch for seat belt	●		Air conditioner only for cooling	○	
	Hydraulic valve overload protection device	●		Air conditioner only for cooling + heater	○	
	Dry powder extinguisher (0.5kg)	○		Front windshield (with wiper/no blow can)	○	
	Dry powder extinguisher (2kg)	○		Rear windshield	○	
Safety	Backward buzzer	●	Lings	Top windshield (without fan)	○	
	Reversing speaker (Chinese)	○		LED rear working lamp (one)	○	
	Electronic upper buffering	○		Rear LED red/blue spot lamp	○	
	Wide- angle central rear view mirror	●		Left, right and rear blue bar	○	
	Rearview mirror on two sides+ Center wide angle rearview mirror	○		Fixed type LED flicker warning lamp	●	
	Reverse radar (4 probes)	○		Fixed type LED rotating warning lamp	○	
	Safety	Reversing image (1 camera + 4 probes)	○	Others	Fixed type LED rotating buzzer warning lamp	○
					Sleeve for steering cylinder	●
					Sleeves for steering cylinder and tilting cylinder	○
					FICS standard type (domestic)	○

Charger

Charger Model		APSP-150V100A-S1	APSP-150V200A-S1
Wiring type		Three-phase four-wiring type	
Power of charger	KVA	≤20	≤40
Air switch model of Upper level power	A	63	80
Input voltage range	Vac	380±15%	
Protection level		IP20	
Working ambient temperature		-20~+45	
Plugs and sockets		Charger meeting national standard	
Charger		Full charging time=required charging capacity/charging current+0.2h. For example: the battery capacity is 153.6V/230Ah, and the discharging state is alarmed by instrument,the charger is 100A, thus the full charging time is 230*0.9/100+0.2≈2.27h	

CPD 40/45/50 G2A11LI



LITON 4-5 t

G2 series lithium battery
powered counterbalance forklift truck



ANHUI HELI CO., LTD.

Add / No.668, FangXing Road, Hefei, China

Fax / +86-551-63639966

Tel / +86-551-63639068(America); 63639258(Europe);

63639358(Asia); 63662105(Africa & Middle East)



LinkedIn



YouTube



Facebook

Based on the platform of internal counterbalance forklift truck

Integrated with electric drive, the truck is powerful and high efficient.



A NEW GENERATION

Smart / Safe / High efficient / Energy saving and environmental protection

Powerful performance, High efficiency and energy saving

- The voltage is increased from 80V of traditional lithium battery powered truck to 153.6V. The overall energy efficiency is significantly improved by increasing of the motor power and reducing of the current of motor and controller.
- Permanent magnet synchronous motor for electric vehicle which has lighter mass compared with the same energy three-phase asynchronous motor is adopted and the comprehensive efficiency is significantly improved.
- Standard load sensing is equipped on the truck as standard which gives priority to steering and saves energy by 5%;

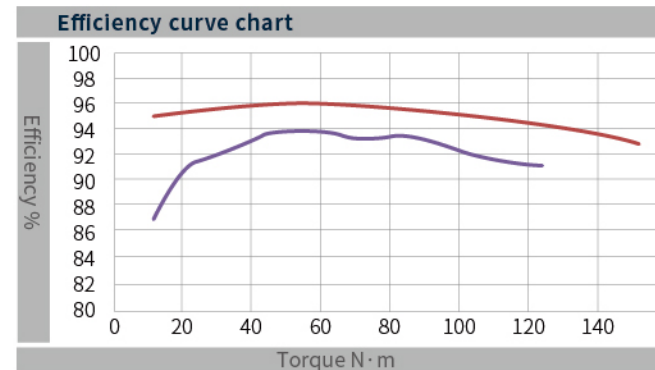

— Driving efficiency of three-phase asynchronous motor on flat ground
— Driving efficiency of permanent magnet synchronous motor on flat ground



The integrated power system reduces the wiring harness which greatly reduces the loss of electric energy transmission. And the levels of parts and control modules are clear and convenient for maintenance;

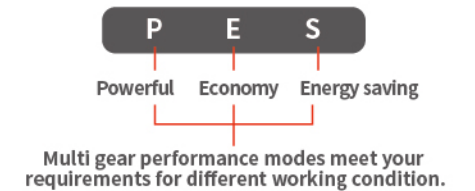
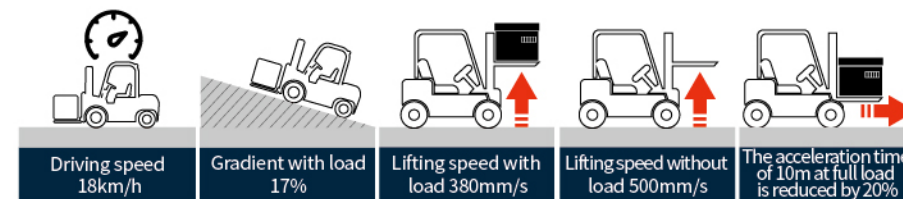

Smart safety functions offer comprehensive guarantee.



Emergency power-off switch is equipped as standard to ensure safety in case of emergency;



High efficiency liquid cooling and heat dissipation system is equipped as standard, which can meet the requirements of automobile S1 continuous working system;



System level voltage safety protection: The truck features integrated / shortest design of voltage connection and multiple insulation monitoring protection;
System level voltage safety sectional design: when the maintenance switch is pulled out, the system fails or the key is disconnected, the voltage system will be automatically disconnected, and the maximum voltage shall not be greater than 76.8v;

- **Steering deceleration function:** the standard steering automatic deceleration function can reduce the risk of tipping when steering;

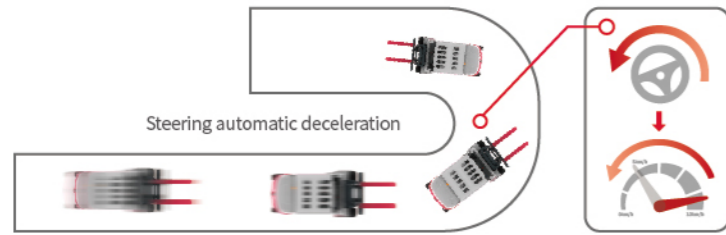

Color screen instrument: it has the functions of full display of truck information, timely reminder and convenient operation;



HELI smart fleet management system (domestic basic edition)

Vehicle positioning	Statistical form
Remote diagnosis	Vehicle management
Remote monitoring	Identification recognition (optional)
Maintenance reminder	Weight management (optional)
Battery management	Collision management (optional)

Internal combustion platform, stable and reliable

- The whole truck is developed based on the internal combustion truck platform, and all parts are mature and reliable. It has the advantages of high performance, high stability and high environmental adaptability of the internal combustion truck, as well as the green and environmental protection characteristics of the lithium truck.



Ergonomic design, intelligent and comfortable

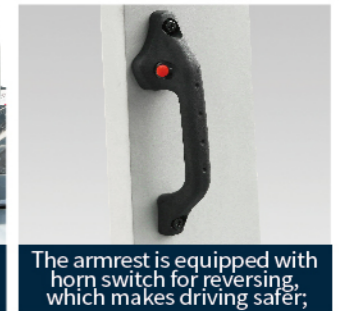
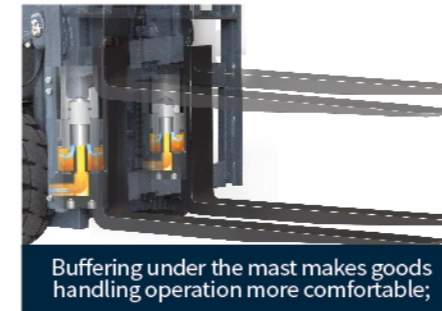

Centralized maintenance points, fast and convenient for maintenance

- The truck features 80° hood opening angle and simple opening mechanism. The key lock is optional.
- Optimized layout of truck structure offers large internal space and convenient maintenance;
- Modular design of power assembly and electrical system offer convenient maintenance and low cost;

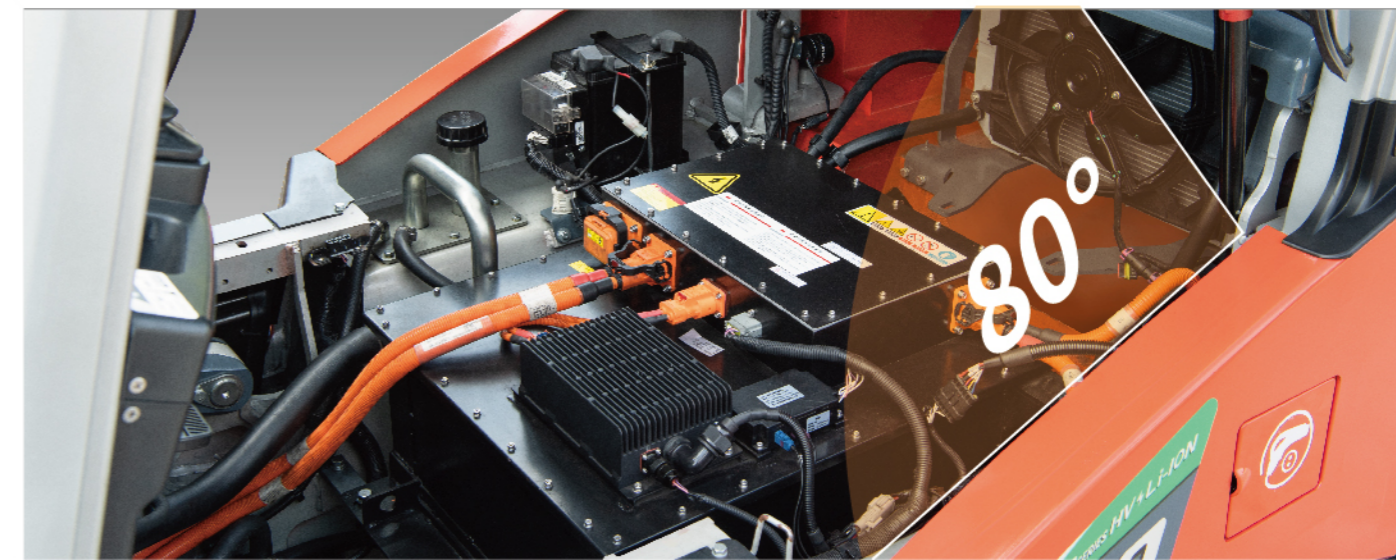

Manufacturer and Technical Data

Characteristics

1.01	Manufacturer		HELI			
1.02	Model		CPD40	CPD45	CPD50	CPD50
1.03	Configuration number		G2A11LI		G2A11LI-600	
1.04	Rated capacity	Q	kg	4000	4500	5000
1.05	Load center distance	c	mm	500		600
1.06	Power mode		Lithium battery			
1.07	Driving mode		Sit-on type			
1.08	Front overhang	x	mm	560		565
1.09	Wheelbase	y	mm	2100		
Weight						
2.01	Total weight		kg	5890/5560	6245/5915	6600/6270
2.02	Axle load (laden,front/rear)		kg	8990/900	9720/1025	10430/1170
2.03	Axle load (unladen,front/rear)		kg	2970/2920	2950/3295	2900/3700
Tyres						
3.01	Tyre type			Solid tyre		
3.02	Tyre size,front			8.25-15		300-15
3.03	Tyre size,rear			7.00-12		
3.04	Wheels,number front/rear(x=driven wheels)			2X/2(Dual tyre 4X/2)		
3.05	Tread, front	b ₁₀	mm	1180		
3.06	Tread, rear	b ₁₁	mm	1190		
Dimensions						
4.01	Mast tilt angle (forward/backward)	α/β	°	6/12		
4.02	Height (mast lowered)	h ₁	mm	2275		
4.03	Free lifting height	h ₂	mm	150		
4.04	Lifting height (standard)	h ₃	mm	3000		
4.05	Max. height,extended (with backrest)	h ₄	mm	4250		4405
4.06	Height of overhead guard	h ₅	mm	2350		
4.07	Seat height relating to SIP (to ground)	h ₇	mm	1080		
4.08	Towing coupling height	h ₁₀	mm	430		
4.09	Overall length (with fork)	l ₁	mm	4255	4275	4325
4.10	Overall length (without fork)	l ₁	mm	3185	3205	3255
4.11	Overall width	b ₁	mm	1480		
4.12	Fork size:thickness x width x length	s/e/l	mm	50x150x1070		55x150x1220
4.13	Fork carriage,according to ISO2328			III		IV
4.14	Distance across fork-arms, Max./Min.	b ₅	mm	1340/300		
4.15	Ground clearance (laden,between mast)	m ₁	mm	150		
4.16	Ground clearance (center of wheelbase)	m ₂	mm	230		
4.17	Right angle stacking aisle width for pallet 1080x1200mm crossways	Ast	mm	4610	4640	4690
4.18	Right angle stacking aisle width for pallet 800x1200mm lengthways	Ast	mm	4810	4840	4890
4.19	Min. outside turning radius	Wa	mm	2850	2880	2930
Performance Data						
5.01	Travel speed (laden/unladen)		km/h	18/19	18/19	18/19
5.02	Lift speed (laden/unladen)		m/s	450/500	420/500	390/500
5.03	Lowering speed (laden/unladen)		m/s	450/450		
5.04	Max.drawbar pull (laden/unladen)		N	23/20		
5.05	Max.gradeability (laden/unladen)		%	19/20	18/20	17/20
Battery						
6.01	Voltage/capacity (Standard/Optional)		V/Ah	Standard153.6/230 Optional153.6/280、153.6/346		
6.02	Mass (Min./Max.)		kg	325/455		
Motor and controller						
7.01	Power of driving motor (S2-60min)		kW	25		
7.02	Power of lifting motor (S3-15%)		kW	20		
7.03	Control mode of driving motor			MOS tube / AC		
7.04	Control mode of lifting motor			MOS tube / AC		
Addition data						
8.01	Service brake/Parking brake			Hydraulic power assisted braking / mechanical- ratchet type		
8.02	Operating pressure for attachments		Mpa	14		

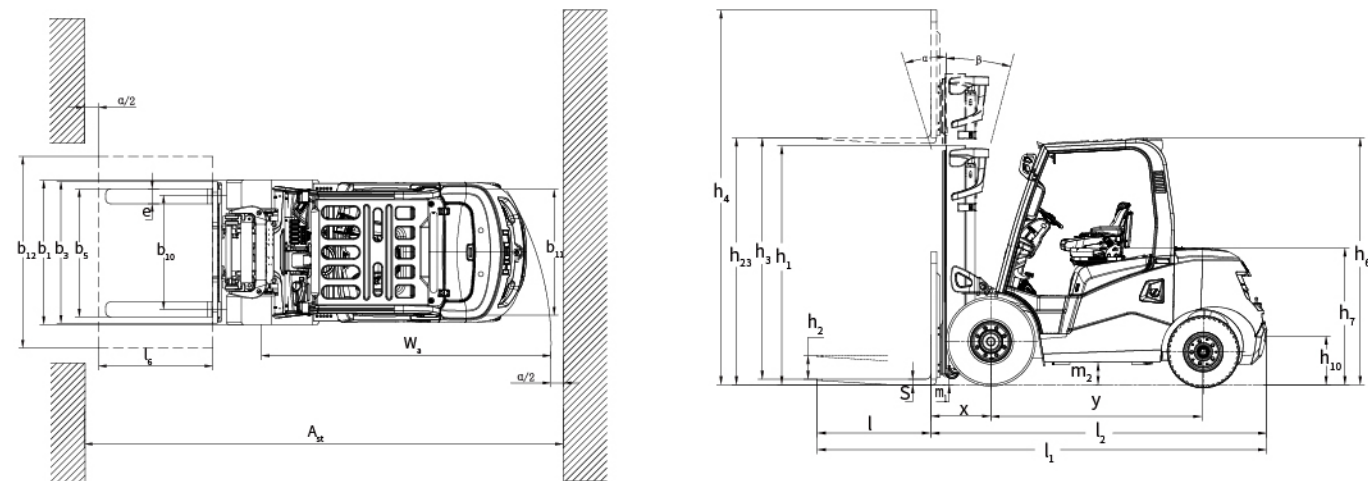

Load curve

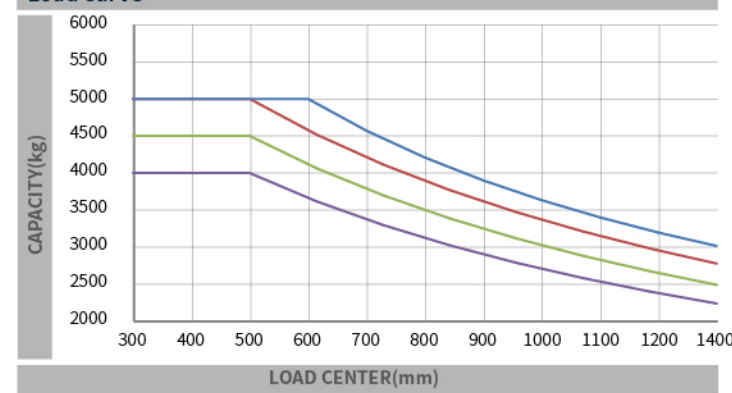

— 5t@600
— 5t@500
— 4.5t@500
— 4t@500

Note: The vertical axis stands for load capacity and the horizontal axis stands for load center which is calculated from the front surface of the forks to the gravity of the standard load. the standard load means a cubic with 1000mm edge length. When mast is tilted forward, using non-standard forks or loading large goods, the load capacity will be reduced. The load capacity of standard mast at different load center can be known from this load chart.

Wide View Standard Mast

Mast model	Max.lifting height (mm)	Load capacity(kg)				Height (mast lowered) (mm)	Free lift (with backrest) (mm)	Service weight (kg)				Mast tilt angle α/β (°)
		4t@500	4.5t@500	5t@500	5t@600			4t@500	4.5t@500	5t@500	5t@600	
M250	2500	4000	4500	5000	5000	1990	150	5825	6180	6535	7000	6/12
M300	3000	4000	4500	5000	5000	2240	150	5890	6245	6600	7050	6/12
M330	3300	4000	4500	5000	5000	2390	150	5930	6285	6640	7080	6/12
M350	3500	4000	4500	5000	5000	2490	150	5855	6210	6565	7095	6/12
M370	3700	4000	4500	5000	5000	2590	150	5980	6335	6690	7115	6/12
M400	4000	4000	4500	5000	5000	2790	150	6070	6425	6780	7195	6/12
M425	4250	4000	4500	5000	5000	2915	150	6105	6460	6815	7220	6/6
M450	4500	3800 4000	4300 4500	4700 5000	4700 5000	3040	150	6135	6490	6845	7240	6/6
M475	4750	3700 4000	4200 4500	4500 5000	4500 5000	3165	150	6165	6520	6875	7265	6/6
M500	5000	3500 3700	4000 4200	4250 4600	4100 4500	3290	150	6200	6555	6910	7290	6/6
M550	5500	3200 3400	3600 4000	4000 4200	3800 4100	3590	150	6315	6670	7025	7385	6/6
M600	6000	*3200	*3600	*3800	*3600	3840	150	6380	6735	7090	7435	6/6

Wide View Full Free 2-Stage Mast

Mast model	Max.lifting height (mm)	Load capacity(kg)				Height (mast lowered) (mm)	Free lift (with backrest) (mm)		Service weight (kg)				Mast tilt angle α/β (°)
		4t@500	4.5t@500	5t@500	5t@600		4t@500	5t@600	4t@500	4.5t@500	5t@500	5t@600	
ZM250	2500	4000	4500	5000	5000	1990	785	640	5828	6183	6538	6969	6/12
ZM300	3000	4000	4500	5000	5000	2240	1035	890	5883	6238	6593	7029	6/12
ZM330	3300	4000	4500	5000	5000	2390	1185	1040	5923	6278	6633	7074	6/12
ZM350	3500	4000	4500	5000	5000	2490	1285	1140	5948	6303	6658	7094	6/12
ZM370	3700	4000	4500	5000	5000	2590	1385	1240	5973	6328	6683	7124	6/12
ZM400	4000	4000	4500	5000	5000	2790	1585	1440	6063	6418	6773	7214	6/12
ZM425	4250	4000	4500	5000	5000	2915	1710	1565	6103	6458	6813	7254	6/6
ZM450	4500	3800 4000	4300 4500	4700 5000	4700 5000	3040	1835	1690	6143	6498	6853	7294	6/6
ZM475	4750	3700 4000	4200 4500	4500 5000	4500 5000	3165	1960	1815	6183	6538	6893	7339	6/6
ZM500	5000	3500 3700	4000 4200	4250 4600	4100 4500	3290	2085	1940	6218	6573	6928	7374	6/6
ZM550	5500	3200 3400	3600 4000	4000 4200	3800 4100	3590	2385	2240	6333	6688	7043	7489	6/6
ZM600	6000	*3200	*3600	*3800	*3600	3840	2635	2490	6383	6738	7093	7544	6/6

Note: 4-5t@500 the free lifting height is increased by +295mm when there is no backrest.
5t@600 the free lifting height is increased by +447mm when there is no backrest.

Wide View Full Free 3-Stage Mast

Mast model	Max.lifting height (mm)	Load capacity(kg)				Height (mast lowered) (mm)	Free lift (with backrest) (mm)		Service weight (kg)				Mast tilt angle α/β (°)	
		4t@500	4.5t@500	5t@500	5t@600		4t@500	5t@600	4t@500	4.5t@500	5t@500	5t@600		
ZSM360	3600	3800 4000	4350 4500	4800 5000	4800 5000	1940	1990	730	630	6048	6403	6758	7243	6/6
ZSM400	4000	3800 4000	4350 4500	4800 5000	4800 5000	2080	2130	870	770	6098	6453	6808	7308	6/6
ZSM435	4350	3800 4000	4350 4500	4800 5000	4800 5000	2190	2240	980	880	6143	6498	6853	7333	6/6
ZSM450	4500	3800 4000	4350 4500	4800 5000	4800 5000	2240	2290	1030	930	6158	6513	6868	7353	6/6
ZSM470	4700	3500 3800	4000 4300	4500 4800	4500 4800	2305	2355	1095	995	6183	6538	6893	7378	6/6
ZSM500	5000	3300 3500	3800 4000	4300 4600	4100 4500	2440	2490	1230	1130	6233	6588	6943	7428	6/6
ZSM540	5400	3250 3400	3700 4000	4200 4500	3800 4100	2590	2640	1380	1280	6343	6698	7053	7543	6/6
ZSM600	6000	*3200	*3400	*3800	*3600	2790	2840	1580	1480	6413	6768	7123	7618	6/6
ZSM650	6500	*2500	*2800	*3200	*3100	2990	3040	1780	1680	6488	6843	7198	7698	6/6
ZSM700	7000	*1800	*2000	*2500	*2500	3165	3215	1955	1855	6553	6908	7263	7763	6/6

Note: 4-5t@500 the free lifting height is increased by +340mm when there is no backrest.
5t@600 the free lifting height is increased by +430mm when there is no backrest.